



marco de carlo

marco de carlo



difference

**brilliance** - contemporary designs

**elegance** - modern classic

**spectrum** - multi coloured jade

**evolution** - fossil sculpture

**refraction** - contemporary stained glass shades

**colours** - stone & glass colour samples

marco de carlo

brilliance range

ferrara

sienna

alessandria

pompeii

merrano

sassari

savona

novara

piacenza

san marino

brilliance range

marco de carlo

---

ferrara

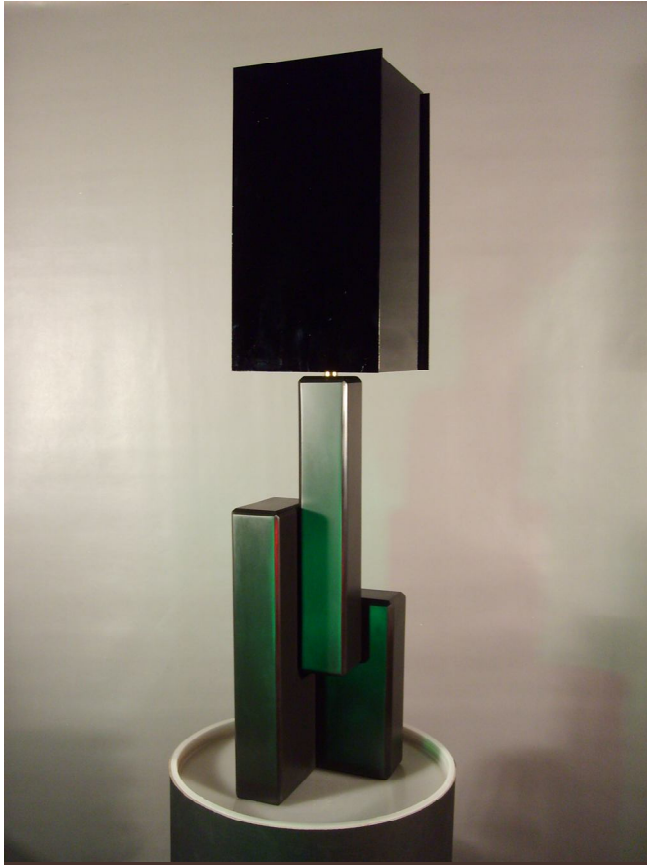

Depicted in the satin finish effect of honed Italian Black Slate with the Z010 stained glass shade.

---

marco de carlo

ferrara

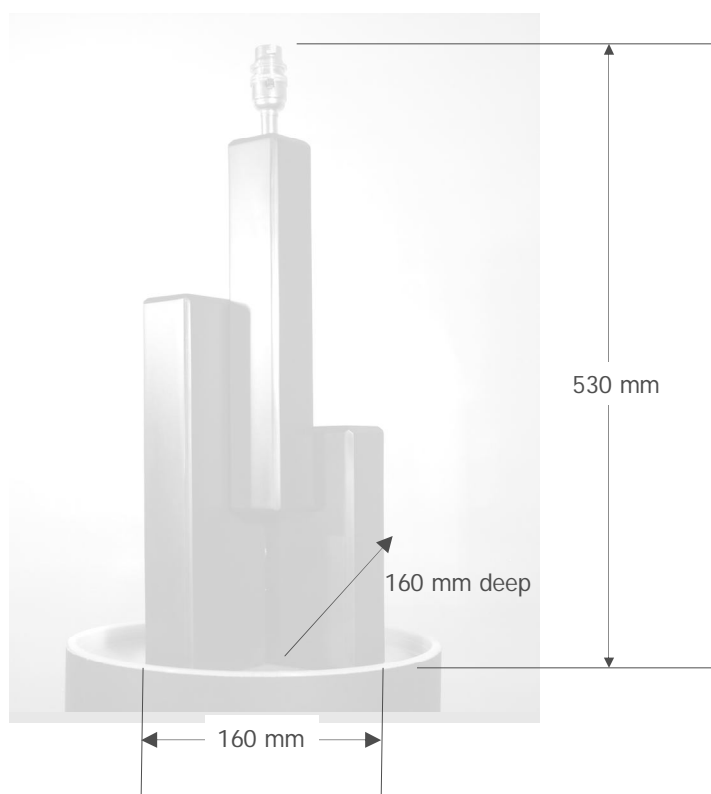

Available in all colours except Spectrum Jade

marco de carlo

---

siena



Nero Marquina Marble and the unusual BW013 stained glass shade.

---

marco de carlo

siena

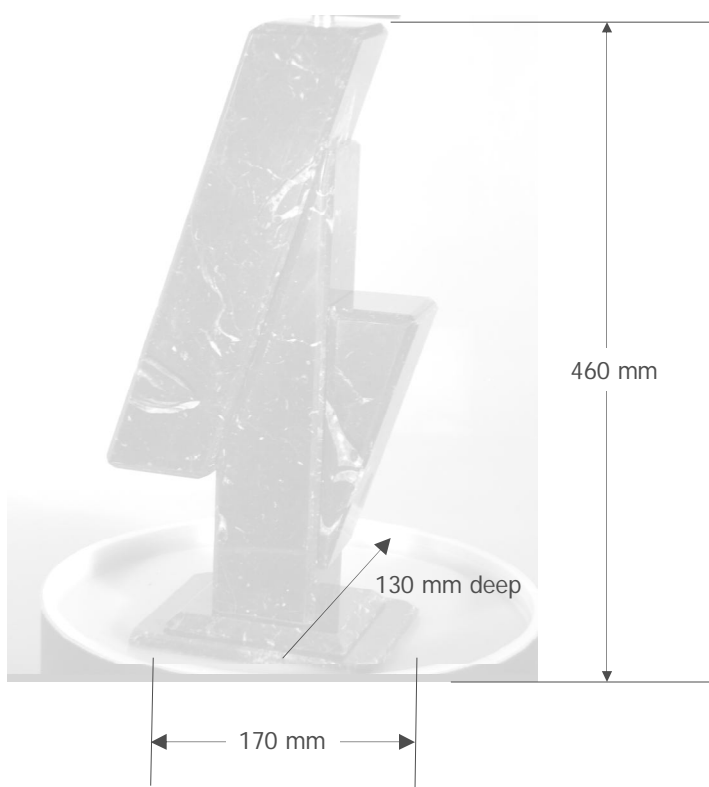

Available in all colours except Spectrum Jade

marco de carlo

---

alessandria



Shown in Nero Marquina Marble, this popular lamp is one of Marco de Carlo's original designs.

---

marco de carlo

alessandria



Available in all colours except Spectrum Jade

marco de carlo

---

Pompeii



Shown here in honed Italian Black Slate along with the RW003 stained glass shade.

---

marco de carlo

pompeii

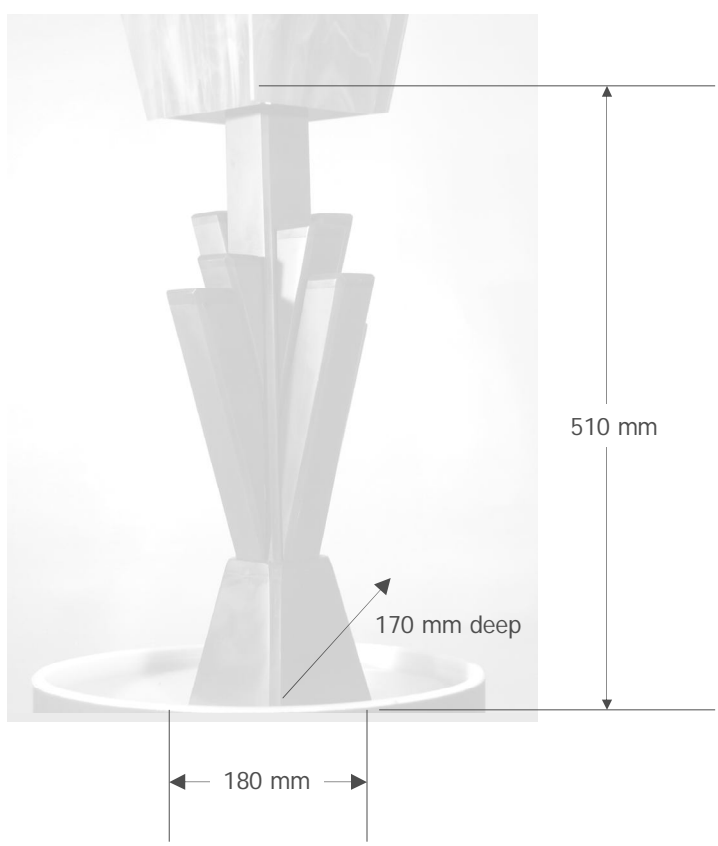

Inspired by Vesuvius available in all colours except Spectrum Jade

marco de carlo

---

merano



The imposing merano is at its best in honed Italian Black Slate photographed here with its respectively angled GW004 stained glass shade.

---

marco de carlo

merano

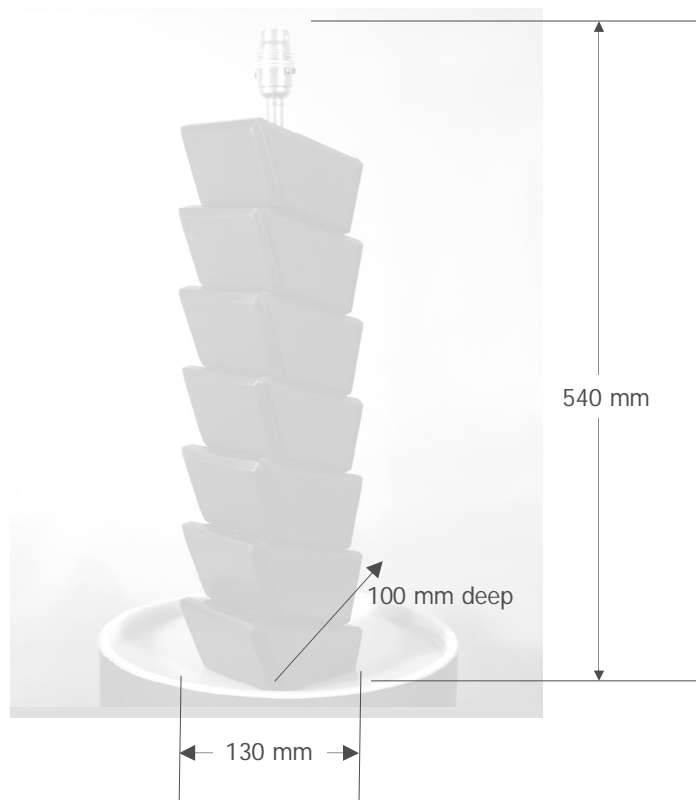

Designed for Italian Black Slate but available in all colours except Spectrum Jade at an additional cost.

marco de carlo

---

sassari

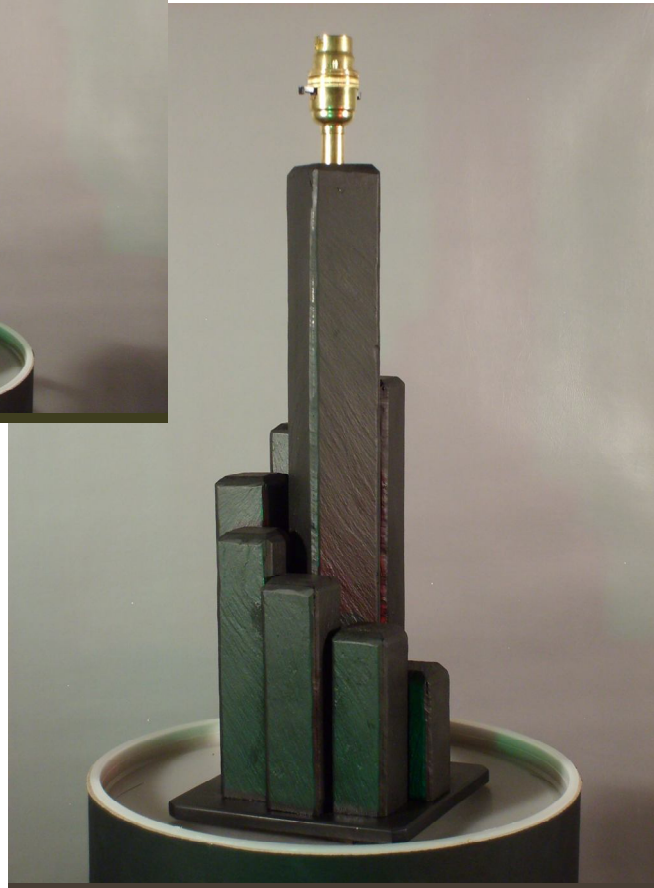

The renowned riven texture of Italian Black Slate suits this design. Photographed with the RW008 stained glass shade.

---

marco de carlo

sassari

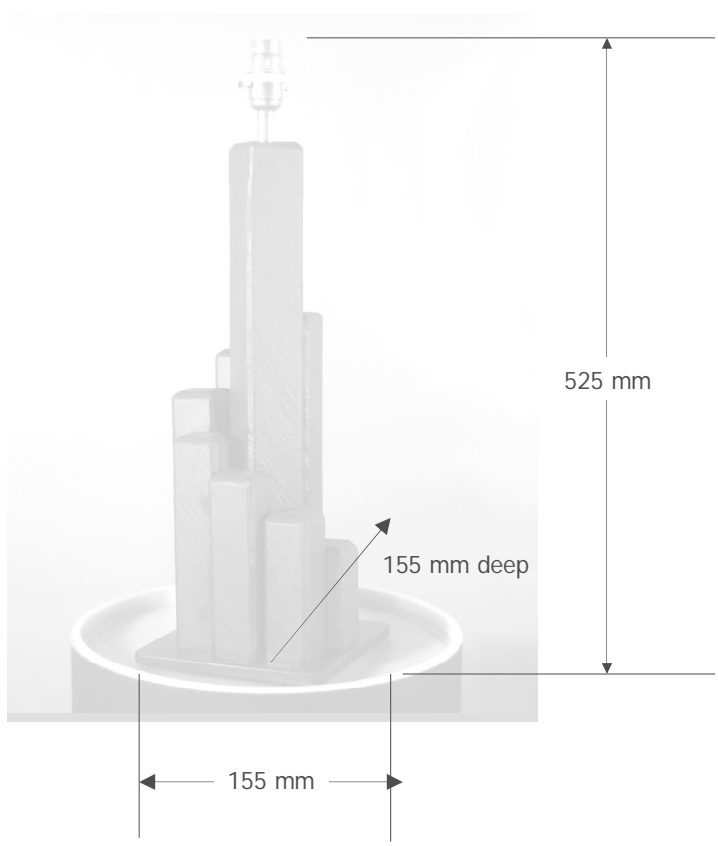

Available in all colours except Spectrum Jade

marco de carlo

---

savona

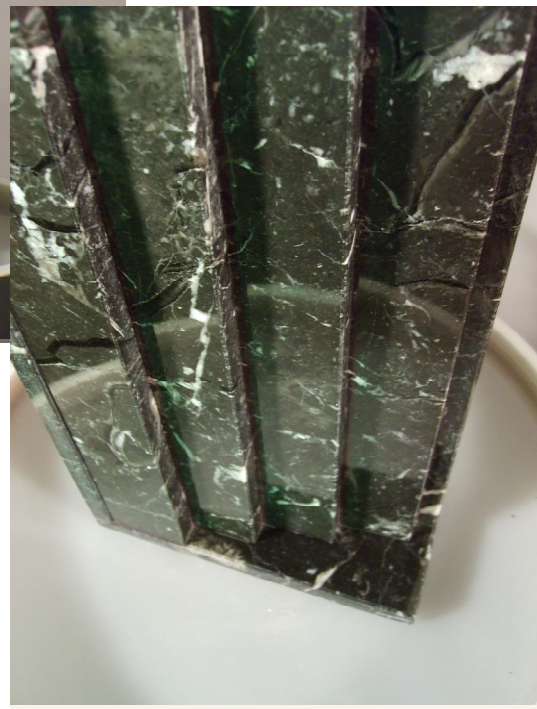

The Savona's design of simple straight line steps can be produced left handed or right handed.

---

marco de carlo

savona

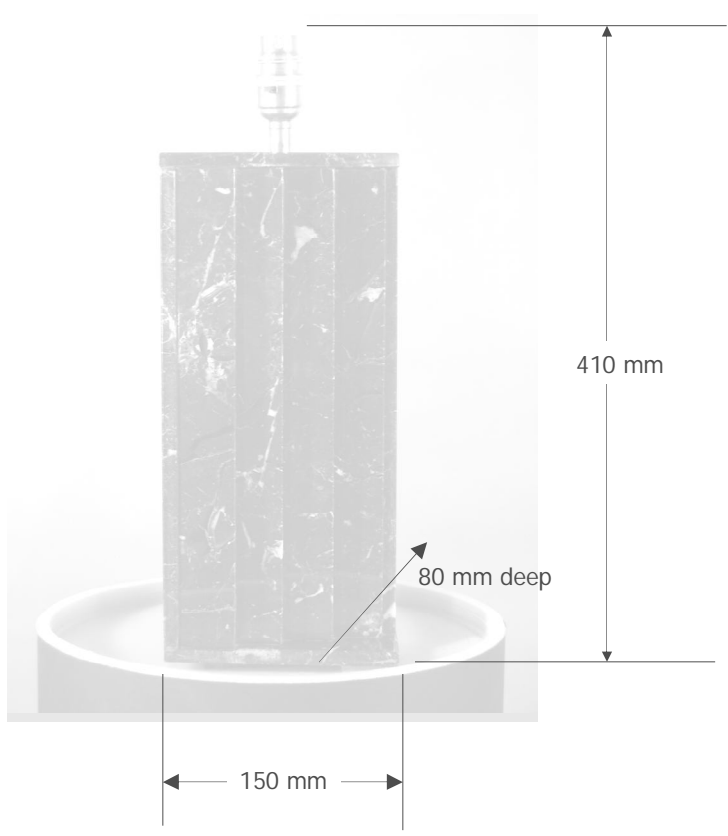

Available in all colours except Spectrum Jade

marco de carlo

---

novara



The Novara in Honed Italian Black Slate with the Z012 stained glass shade.

---

marco de carlo

novara

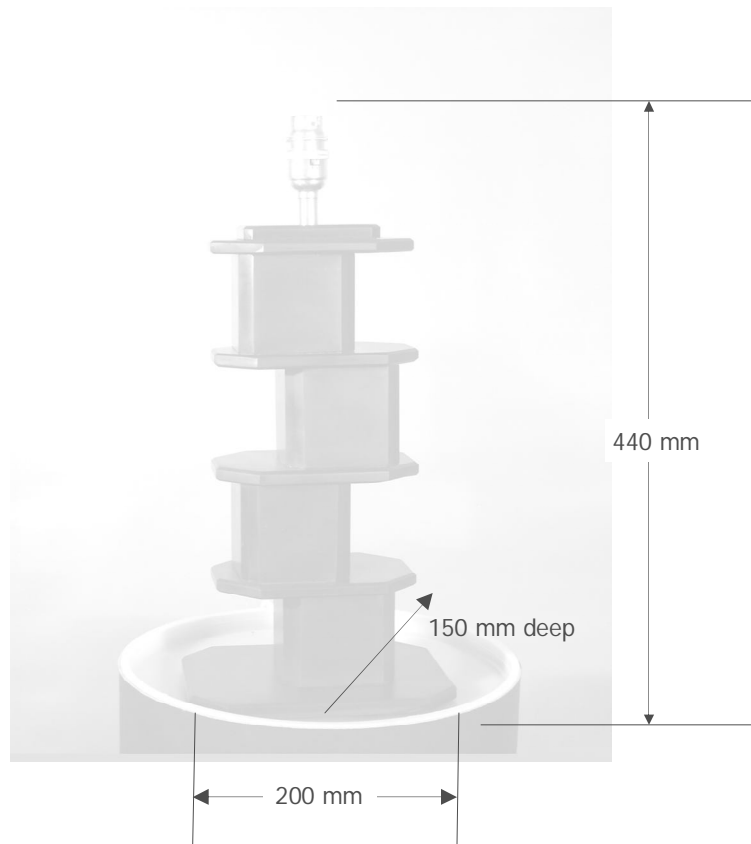

Available in all colours except Spectrum Jade

marco de carlo

---

piacenza



The split column allows for a combination of two colours if required. Shown here in Arabescato Marble. with the W006 shade.

---

marco de carlo

piacenza

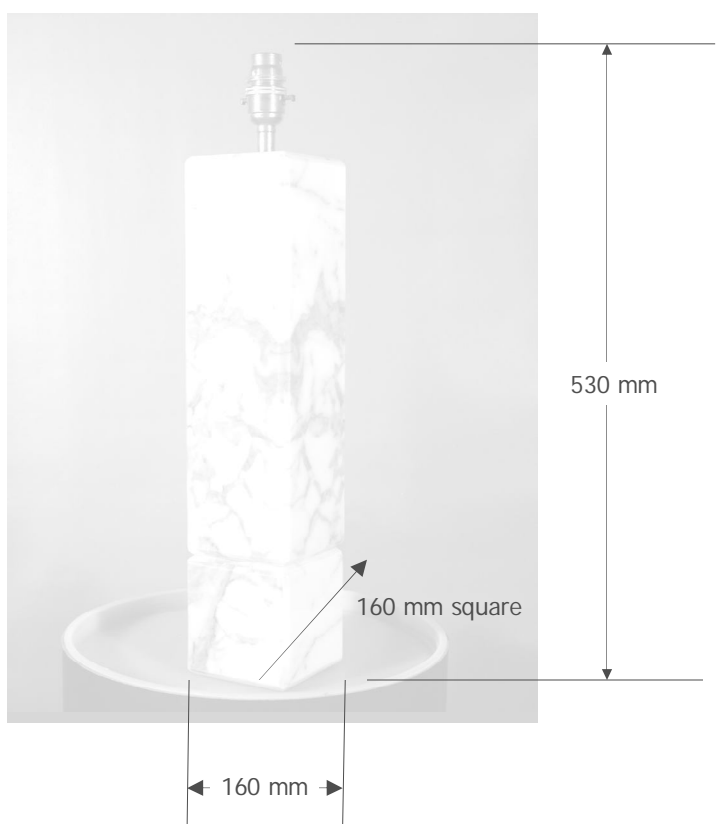

Available in all colours except Spectrum Jade

marco de carlo

---

san marino

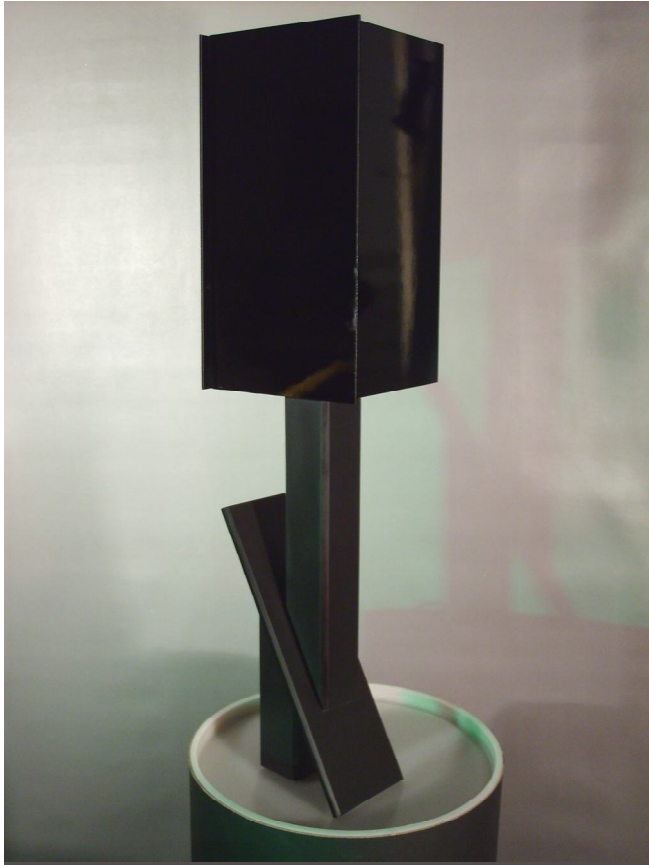

A simple yet stylish design inspired by the Earth's natural geological faults.

---

marco de carlo

san marino

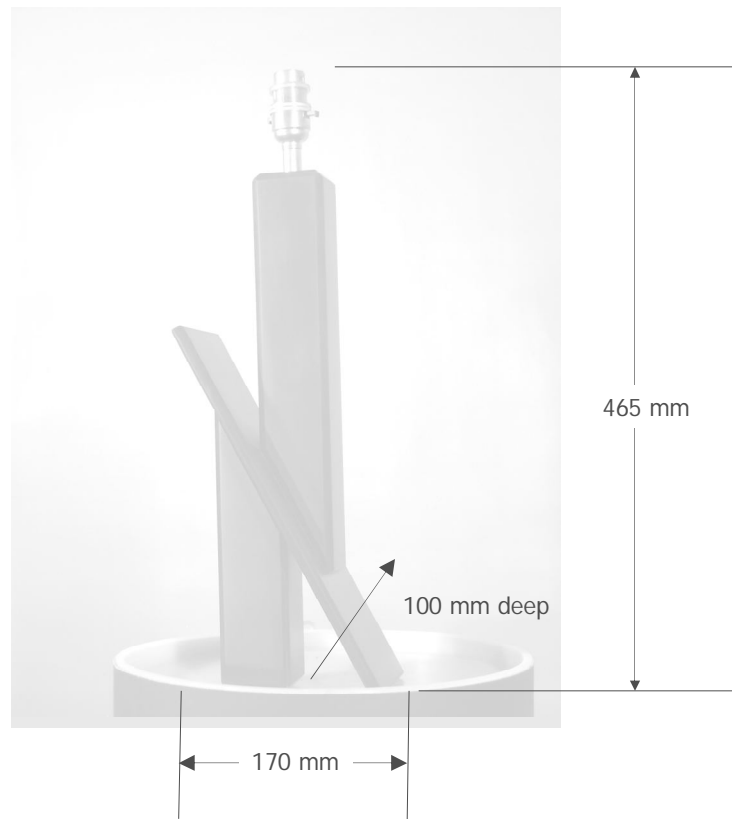

Available in all colours except Spectrum Jade

marco de carlo

---

elegance range

messina

Latina

turin

bologna

milano

genoa

palermo

barletta

benevento

corsica

romano

rimini

lombardia

perugia

monza

elegance range

marco de carlo

---

messina



An inspiration from the prominent statues & obelisks of ancient Rome pictured in Palissandro Bluette marble.

---

marco de carlo

messina

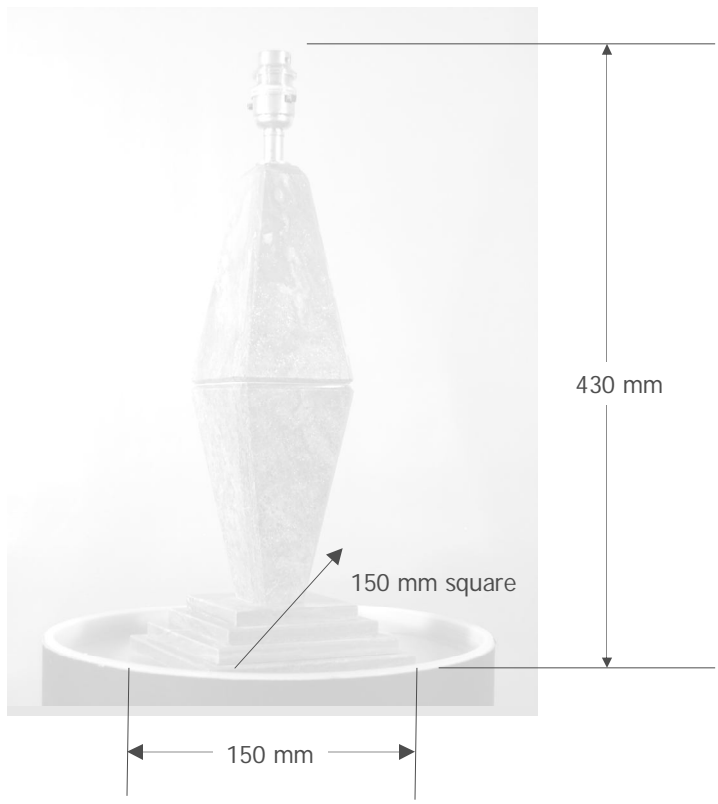

Available in all colours except Spectrum Jade

marco de carlo

---

latina



This design is best suited to Crema Marfil marble as pictured above

---

marco de carlo

latina

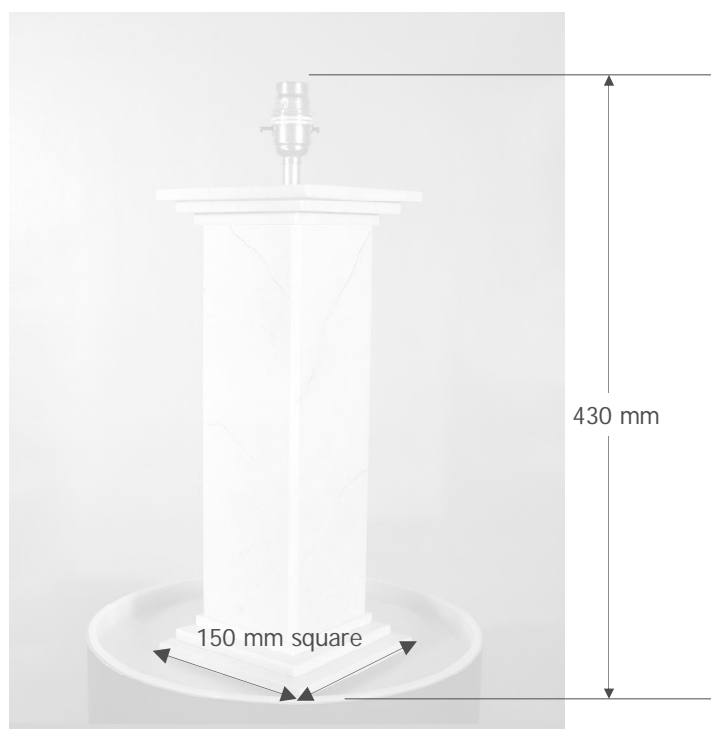

Available in all colours except Spectrum Jade

marco de carlo

turin



One of Marco de Carlo's original designs at its best when built with 2 suited colours of stone. Pictured with the AW005 stained glass shade.

---

marco de carlo

turin

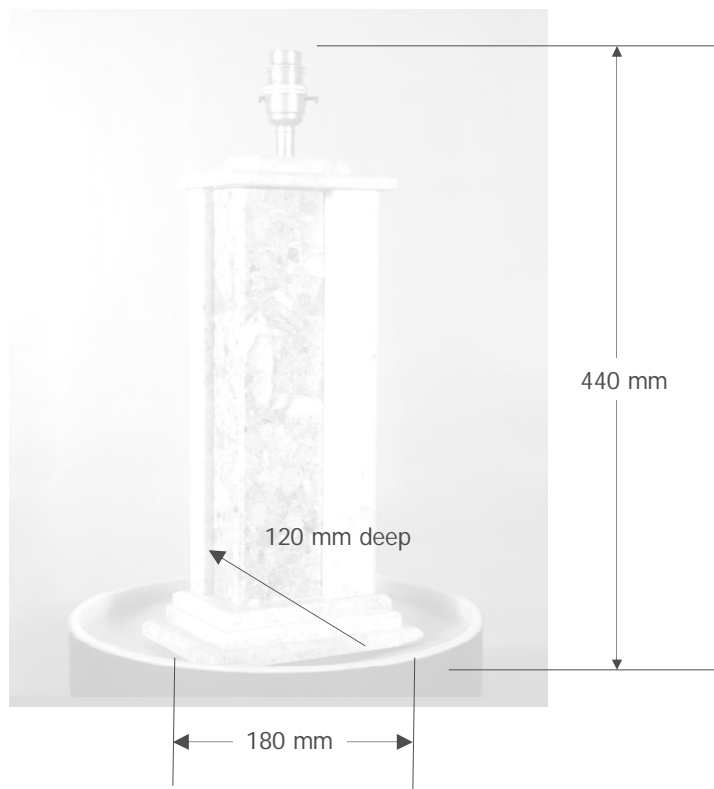

Available in all colours except Spectrum Jade

marco de carlo

bologna



An inverted obelisk where adjacent sides taper in opposite directions creating a deceptive illusion to the eye when viewed close up. Photographed in Travertine Noce

---

marco de carlo

bologna

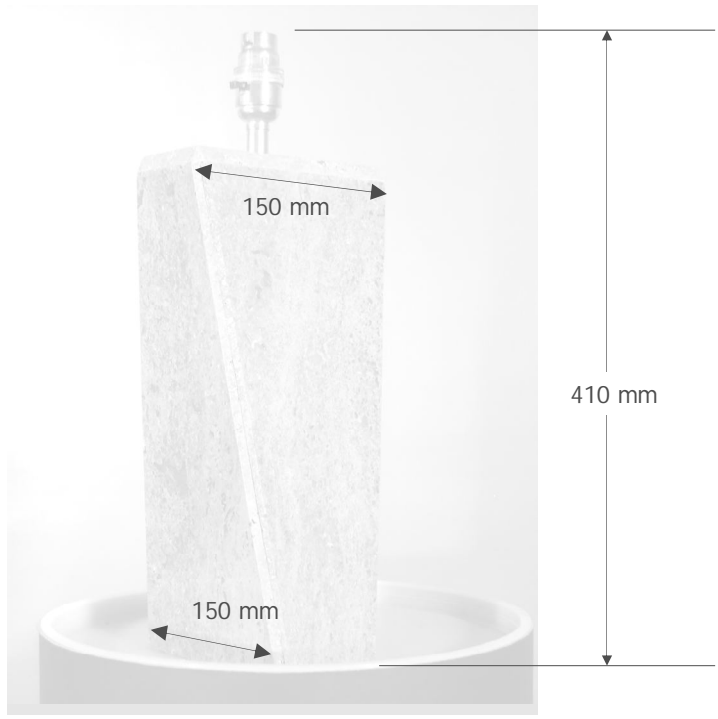

Available in all colours except Spectrum Jade

marco de carlo

milano



The very first Marco de Carlo design has 28 edges cut and polished at 45 degrees. Pictured in Crema Marfil marble.

---

marco de carlo

milano

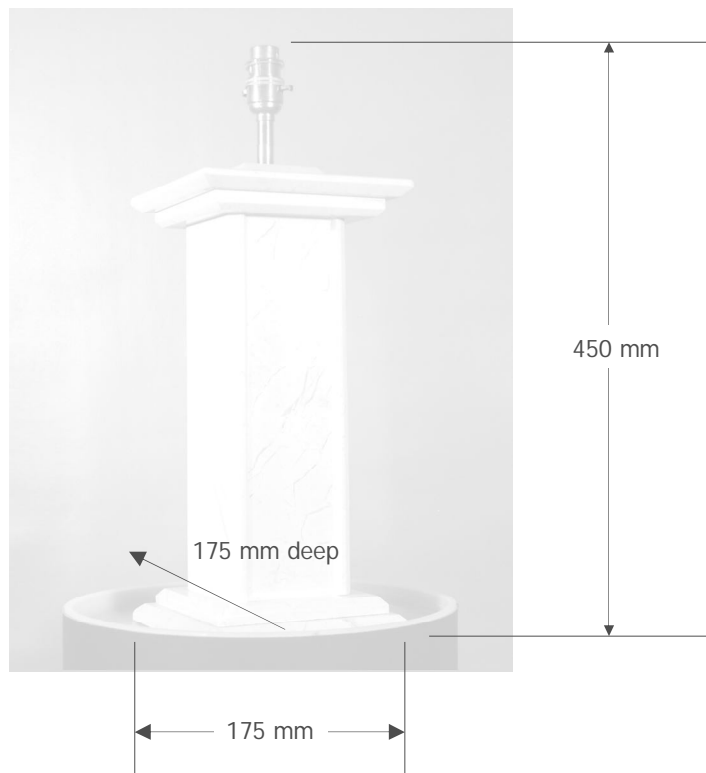

Available in all colours except Spectrum Jade

marco de carlo

---

genoa



A traditional impression ideal for many colour variations, shown here in Rosso Alicante (red) & Nero Marquina (black).

---

marco de carlo

genoa

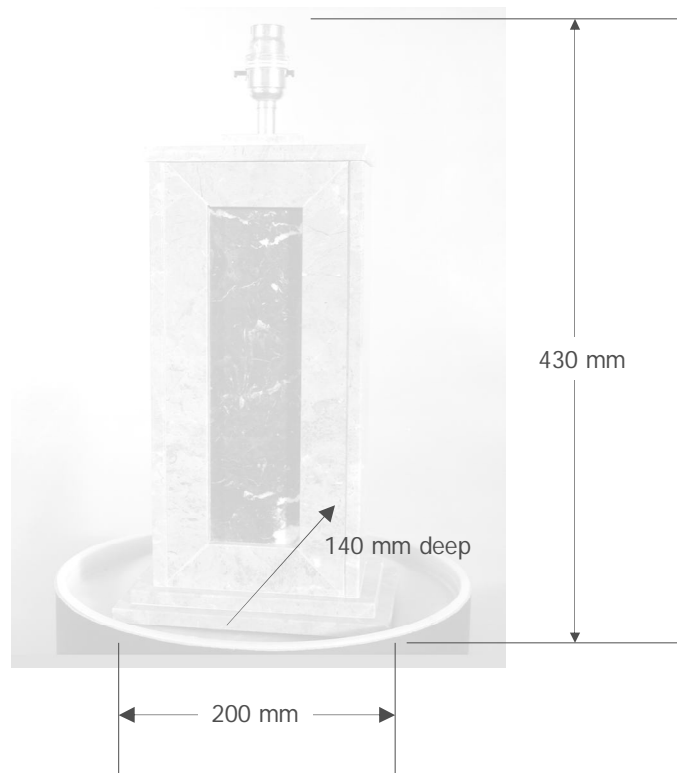

Available in all colours except Spectrum Jade

marco de carlo

---

palermo

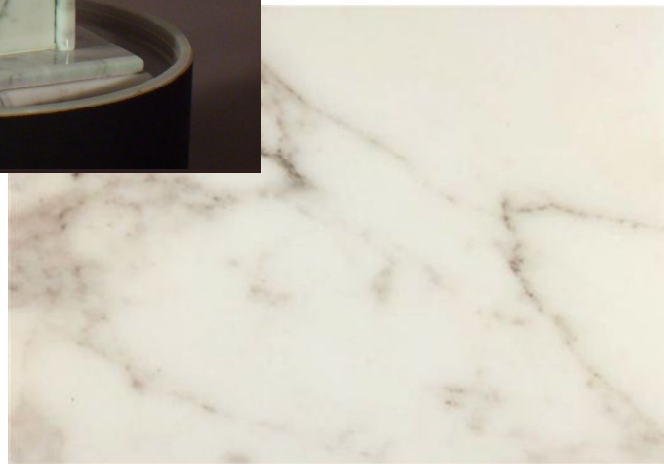

Pictured in Arabescato marble.

---

marco de carlo

palermo

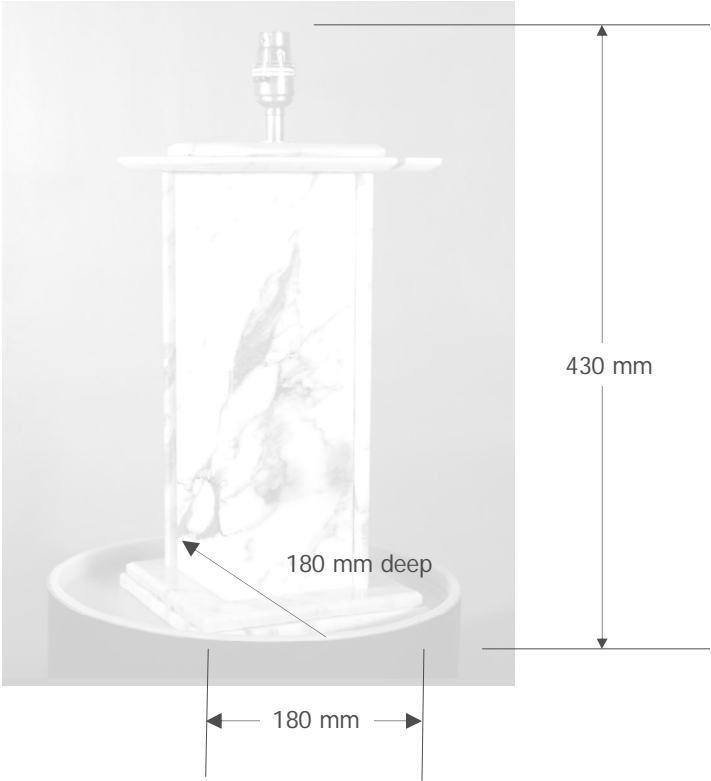

Available in all colours except Spectrum Jade

marco de carlo

---

barletta



Calacatta Oro marble (white with brown veins) & Marron Imperial marble (brown with white veins) are the stones shown above.

---

marco de carlo

barletta

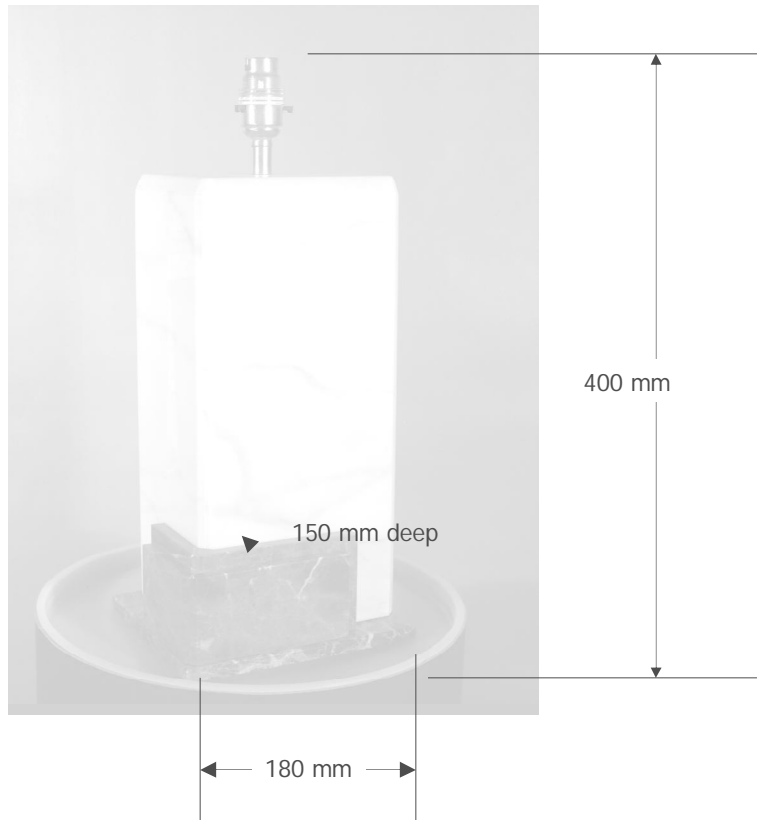

Available in all colours except Spectrum Jade

marco de carlo

---

benevento

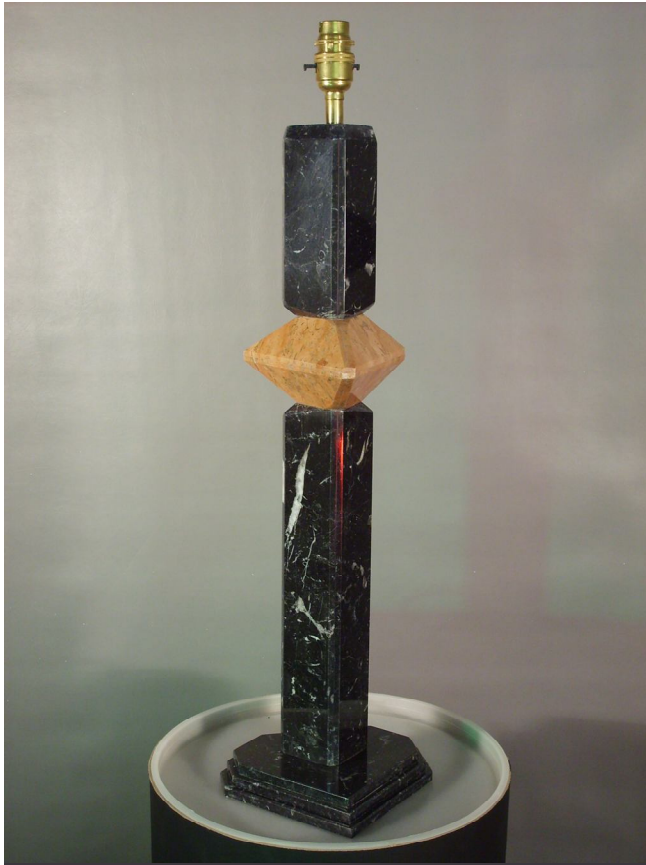

Illustrated in Nero Marquina & Rosso Alicante marble.

---

marco de carlo

benevento

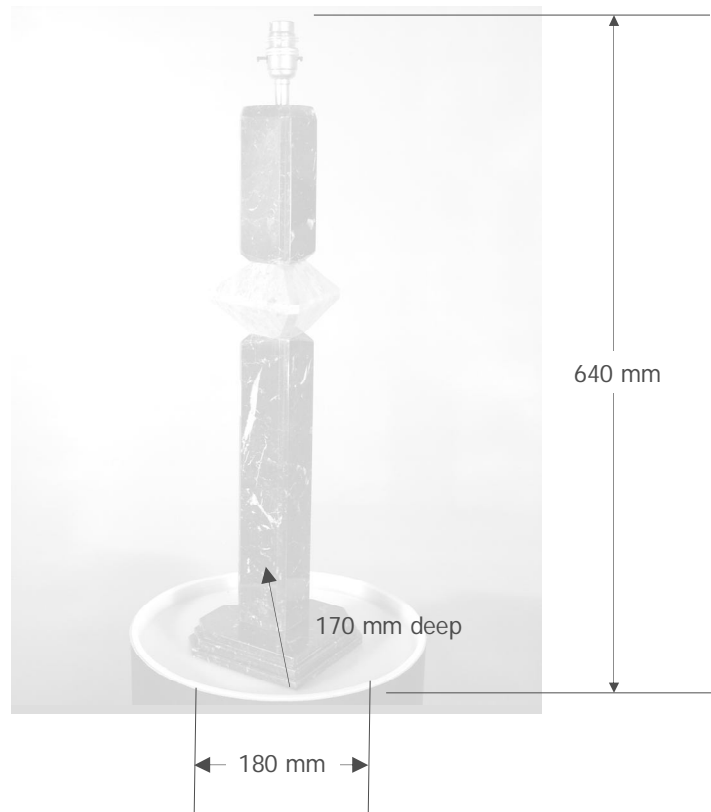

Available in all colours except Spectrum Jade

marco de carlo

---

romano

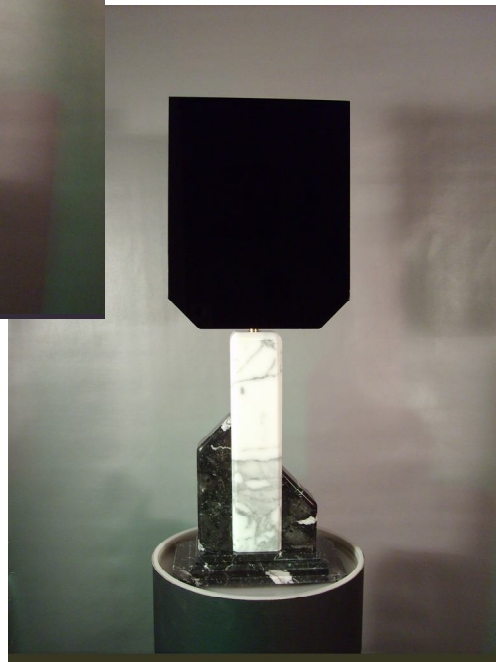
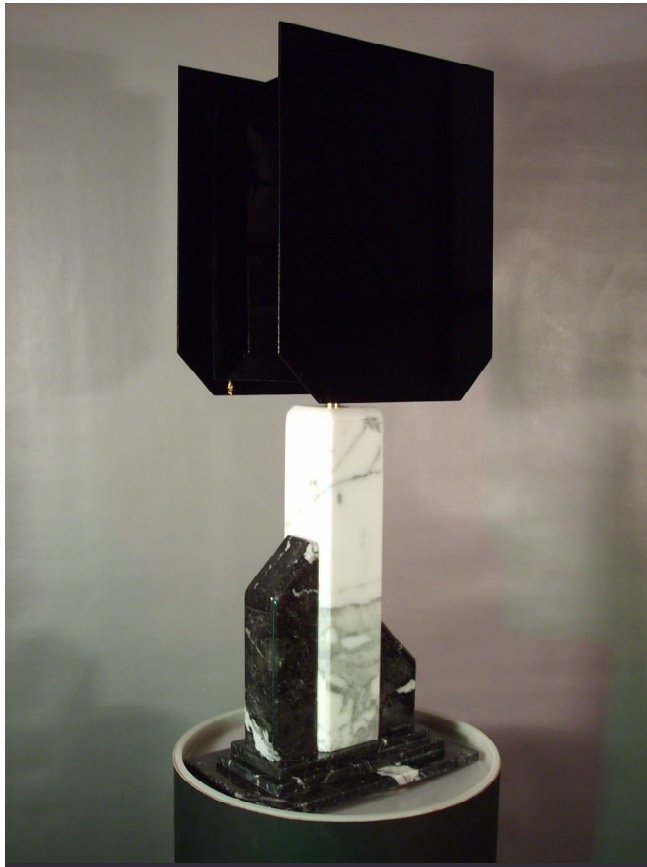

Illustrated above in Nero Marquina marble & Arabescato marble, this lamp has a distinctive Art Deco feel.

---

marco de carlo

romano

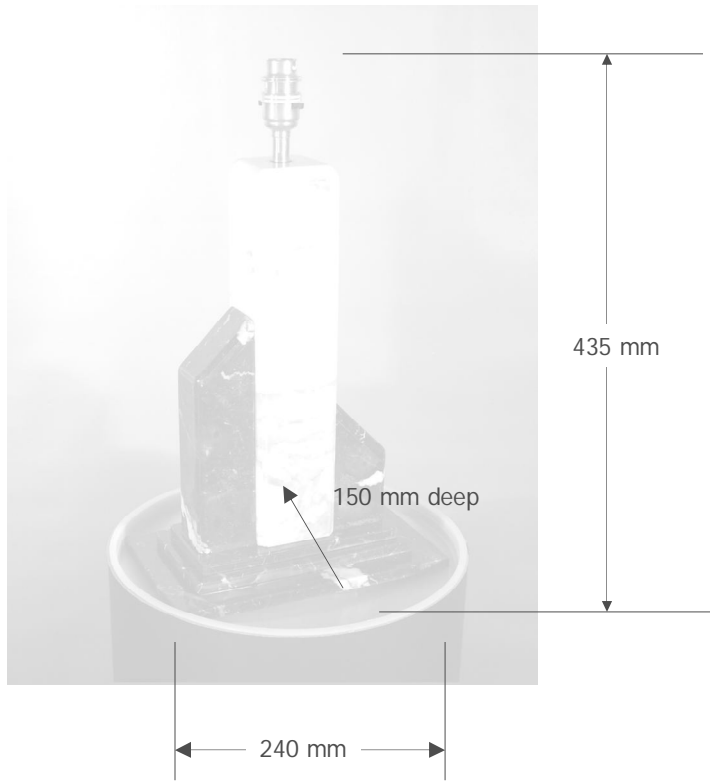

Available in all colours except Spectrum Jade

marco de carlo

---

rimini

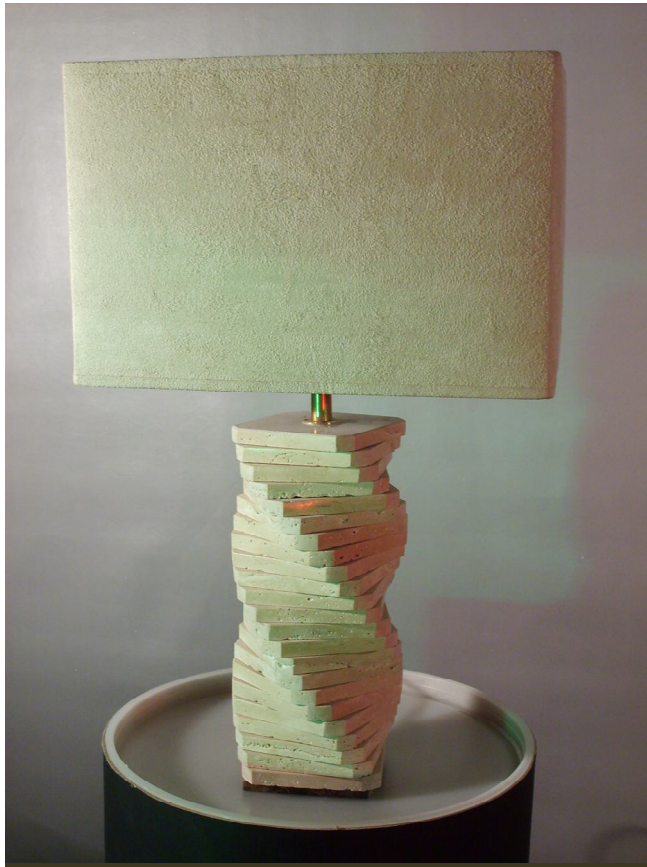

Illustrated in Travertine Crema

---

marco de carlo

rimini

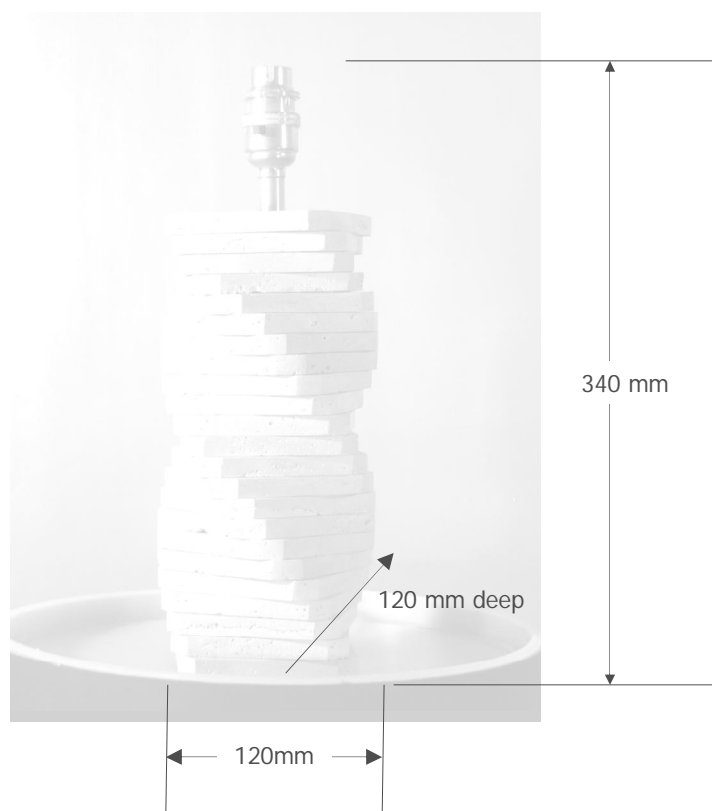

Can be produced to any custom height and width.

Available in Travertine Noce & Travertine Crema. Other stones are available at additional cost.

marco de carlo

---

lombardia

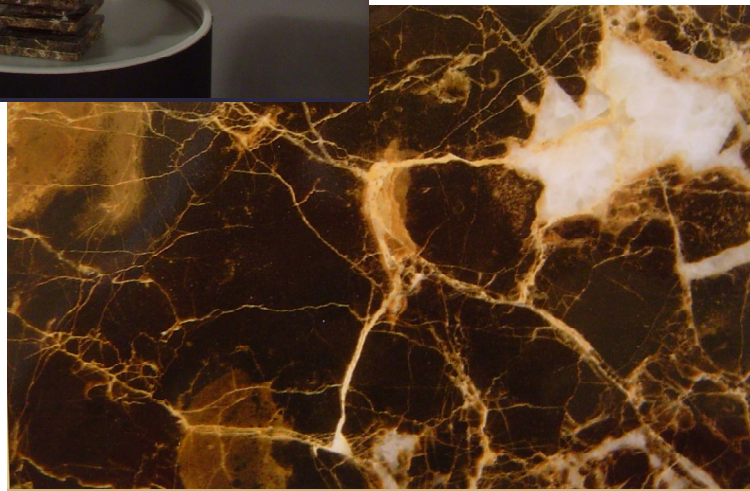

Pictured in Marron Imperial marble displaying the typical veins of the classic marble effect

---

marco de carlo

lombardia

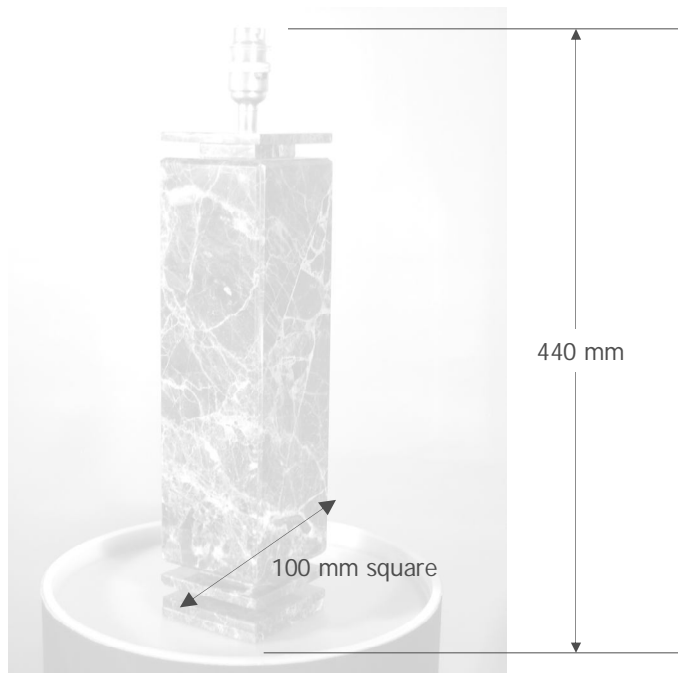

Available in all colours except Spectrum Jade

marco de carlo

---

perugia

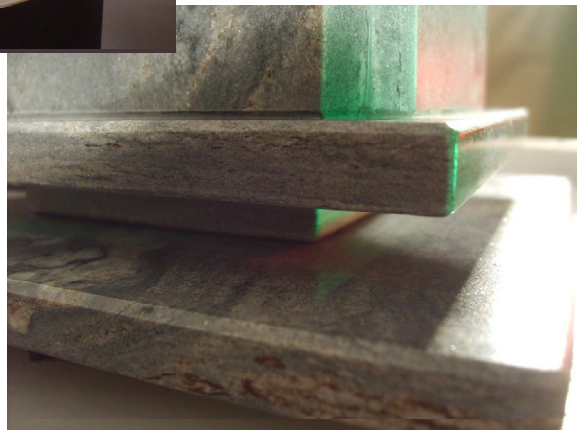

Photographed in Palissandro Bluette marble.

---

marco de carlo

perugia

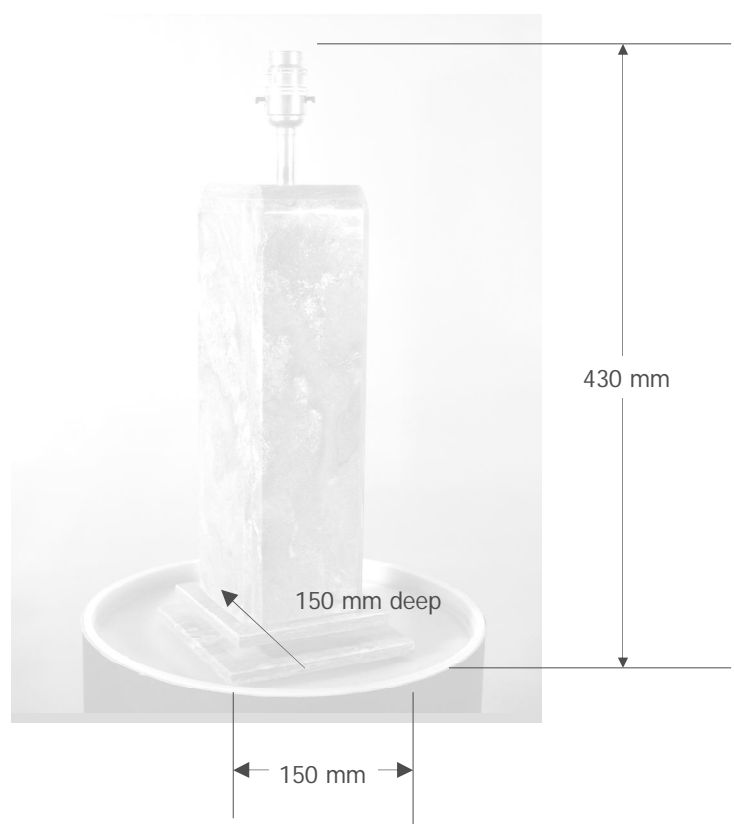

Available in all colours except Spectrum Jade

marco de carlo

spectrum range

005 multi colour

005 blue

013 multi colour

013 blue

spectrum range

marco de carlo

---

## 005 Spectrum

---



Above Right: Covering the colours of the spectrum, the multi coloured Jade compliments almost any colour scheme. (With RW009 shade)

Above Left: The vivid blue version of the Jade creates a stunning lamp base that works well with lively colours or conservative dark tones. (With GW002 shade).

---

marco de carlo

005 spectrum

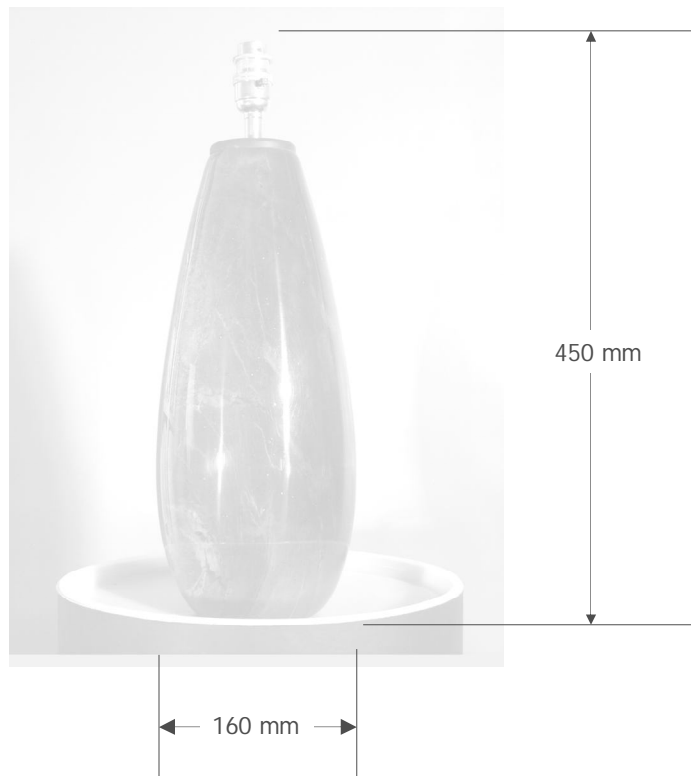

Available in Blue or Multi-Colour Spectrum Jade

marco de carlo

---

## 013 Spectrum

---



Above Left: Covering the colours of the spectrum, the multi coloured Jade compliments almost any colour scheme.

Above Right: The vivid blue version of the Jade creates a stunning lamp base that works well with lively colours or conservative dark tones.

---

marco de carlo

013 spectrum



Available in Blue or Multi-Colour Spectrum Jade

marco de carlo



evolution range

orthoceras

evolution range

new additions will be added to this  
range during 2008

marco de carlo

---

orthoceras

---



Hand carved Sculptures of 500 million year old Orthoceras embedded in Limestone.

---

marco de carlo

orthoceras

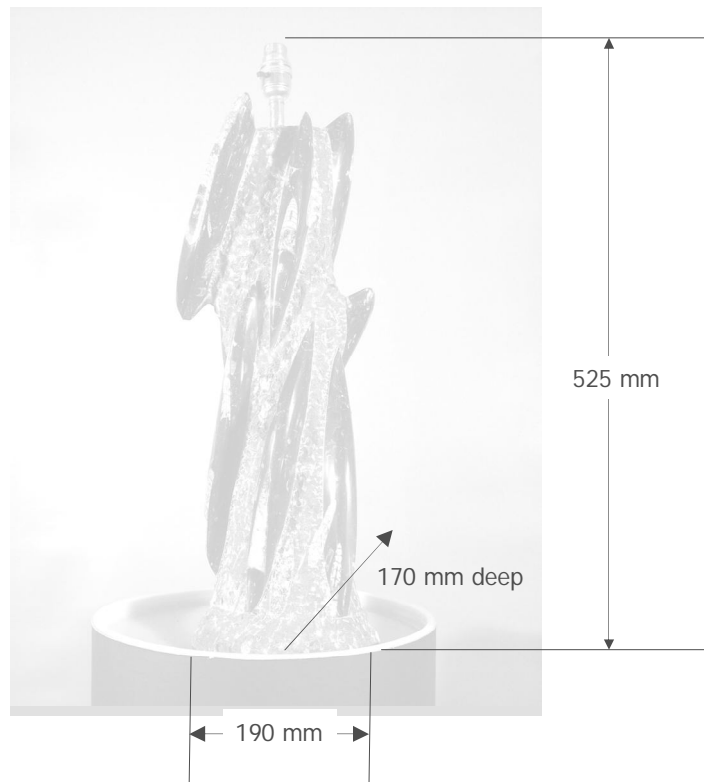

Guide sizes as each sculpture is individual

These lamp bases are hand carved out of the limestone from beneath the Sahara Desert in which the fossils were embedded 500 million years ago. Each lamp is sculptured according to the position of the fossils therefore each lamp will have its own unique shape.

marco de carlo



refraction range

stained glass shades

produced in any colour (see colours  
section)

refraction range

marco de carlo

---

refraction range



001



002



003



004



005



006



007



008



009



010



011

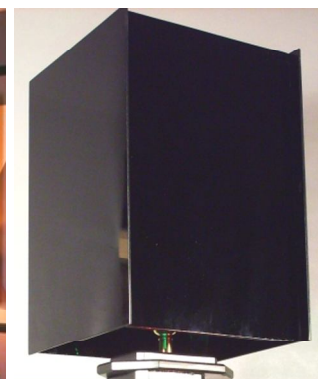

012

Stained Glass imported by Marco de Carlo from the USA is cut and finished to the above designs to suit our lamps respectively. The individual sizes for each shade are detailed overleaf though any bespoke size can be produced, furthermore they can be produced in any choice of colour.

---

**Dimensions of the stain glass shades shown overleaf.**

Shade	Height	Width	Depth
001	300 mm	150 mm	150 mm
002	350 mm	240 mm	240 mm
003	300 mm	240 mm	240 mm
004	300 mm	250 mm	250 mm
005	300 mm	200 mm	150 mm
006	300 mm	200 mm	190 mm
007	300 mm	240 mm	170 mm
008	300 mm	200 mm	200 mm
009	350 mm	230 mm	230 mm
010	300 mm	160 mm	160 mm
011	300 mm	300 mm	300 mm
012	300 mm	220 mm	220 mm

**Order Codes for Stain Glass Shades.**

When ordering shades add the colour code as a prefix to the shade code, i.e. GW004 is the code for the shade type 004 in the Green / White stained glass, GW is the code for green / white glass (see glass colours for the glass codes).

marco de carlo



colours

colours

stained glass colours

stone colours

marco de carlo

---

# stained glass colours

---

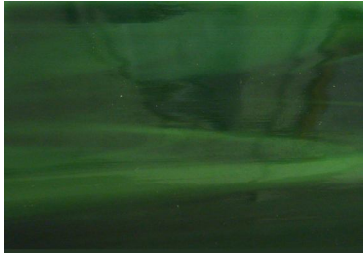

GW - Green / White



KW - Pink / White



AW - Amber / White

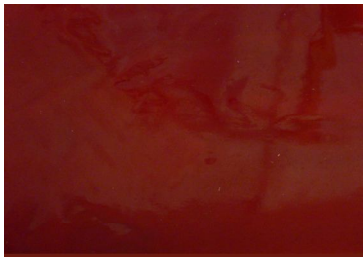

RW - Red / White



BEW - Beige / White

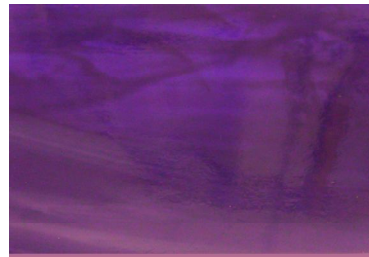

PW - Purple / White



BW - Blue / White



PGW - Pale Green / White

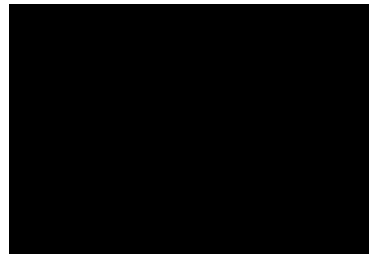

Z - Black



W - White

---

marco de carlo



arabescato

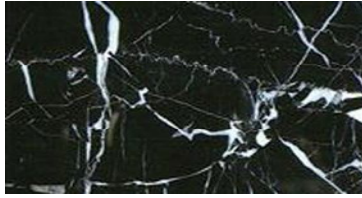

black lightning



crema marfil



nero fossil

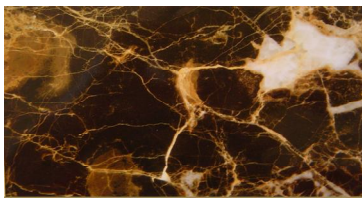

marron imperial



palisandro bluette



rosso verona



crema travertine



bardiglio



botoccino classico



valencia



grigio carnicio



napoleon



rose aurora



salome



travertine noce

stone colours



calacatta oro

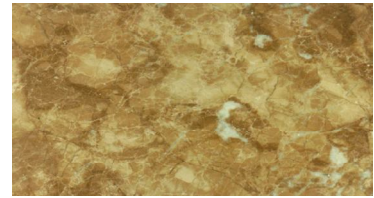

emperador

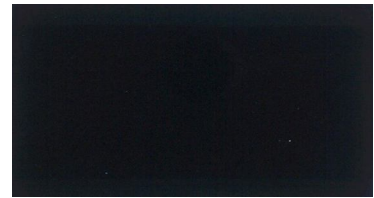

Italian black slate

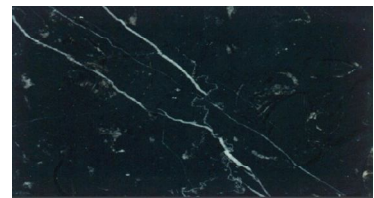

nero marquina

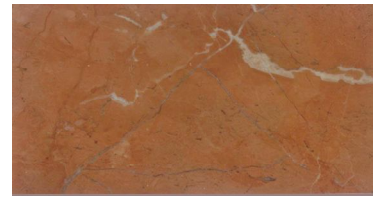

rosso alicante



statuario



verde tinos

marco de carlo



contact

marco de carlo

48a aldenham road

watford

herts

WD23 2NA

+44 (0)1923 242702

[info@marcodecarlo.co.uk](mailto:info@marcodecarlo.co.uk)

[www.marcodecarlo.co.uk](http://www.marcodecarlo.co.uk)